

HT Series –Hydraulic Lift Tables

500 to 2000 lb capacities

The HT series was developed specifically as a heavy-duty material handling table that can be used in confined spaces. Key features include low maintenance, extremely stable, high level of mobility, and an ergonomic design. Several sizes and options are available to suit any customer's material handling requirements.

Their rugged construction consists of steel plate and a welded web frame. The top is guided by extremely rigid guide tubes. These tables are designed to last for decades with very little maintenance in the most demanding environments.

The HT series is engineered with ergonomics in mind. The high capacity hydraulic jack allows the operator to quickly and easily adjust the height of the table with a high level of precision. This allows the operator to have better access to their work piece or to load/unload materials between equipment or storage at different loading levels with less effort.

The high level of mobility is achieved through heavy-duty large diameter steel (standard) or poly-steel (optional) casters. The position of the table can be anchored through its rubber pad telescoping floor lock.

Many options are available to improve ergonomics and productivity. Easier on/off load transfer through conveyor or ball transfer roller tops and manual or electric hydraulic push pull mechanisms (PP series). Powered lift can be achieved through our cost effective electro-mechanical (EM series) tables or the severe service electric hydraulic (EL series). Die and mold specific accessories are also available to ease their separation and positioning them for service accessibility.

Custom designs are possible for your specific needs. Lexco Engineering and Manufacturing has over 50 years of experience and knowledge, which translates into a valuable resource in the material handling industry. Tables with overhanging tops, mounting hole patterns, custom dimensions, and much more can be accommodated.

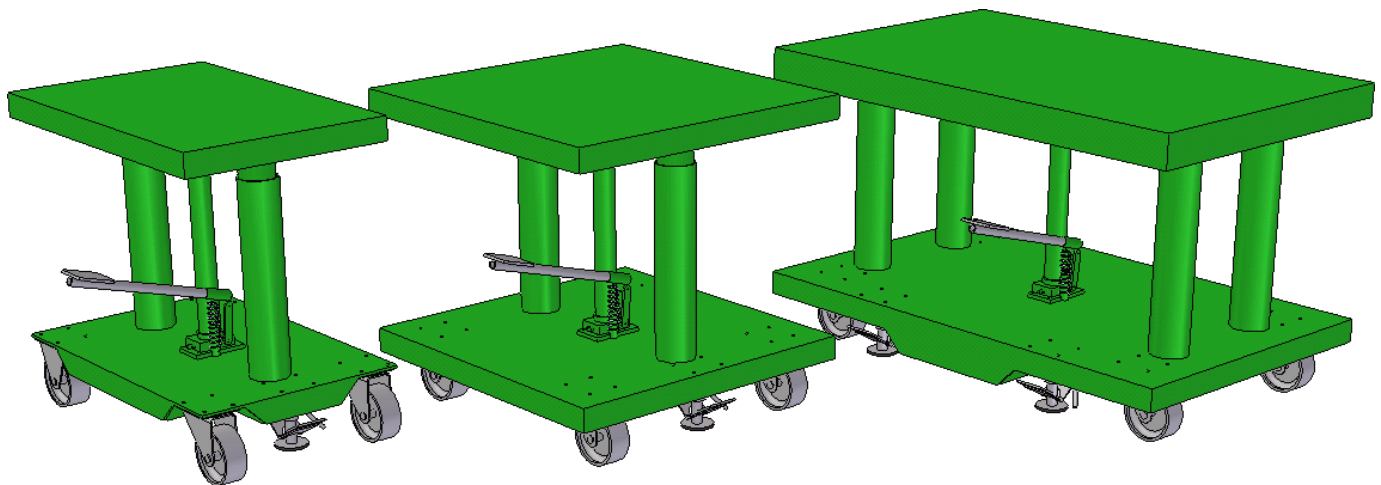
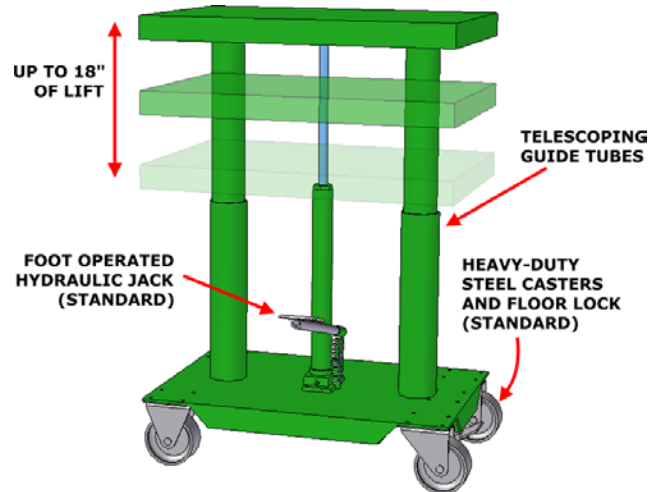

HT-2338-2F

HT-3338-2F

HT-3438-24

HT Series –Hydraulic Lift Tables

500 to 2000 lb capacities

Suggested Applications

- Heavy duty, high capacity mobile utility table.
- Ergonomic adjustable height workbench/workstation.
- Die and mold handlers.

Standard Features

- Heavy-duty steel plate, welded web frame construction.
- Rigid telescoping guide tubes.
- Treadle guide provides superior durability and ergonomics.
- Foot operated hydraulic release lever.
- Sure-grip rubber pad telescoping floor lock.
- Low rolling resistance, heavy duty steel or poly-steel wheels.

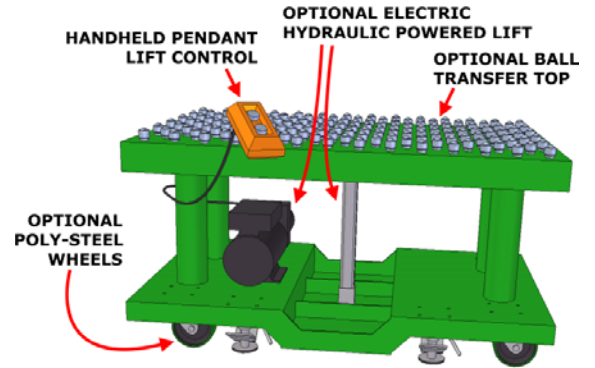

EL-3468-24

Available Options

- Push handle, guide tube covers (bellows), and extended top plate clamp lip.
- Zero drift mechanical height locks for long term position holding.
- Tool safe soft top and 2.5" clamp lip top for work bench applications.
- Ergonomic AC or DC electro-mechanical (EM Series) or electric hydraulic (EL Series) powered lift with hand held pendant for remote operation.
- Conveyor or ball transfer tops with or without manually operated push pull mechanism (HTP Series).
- Die handling boom for die separation and maintenance (DH Series).

Size and Capacity*

Model No.	Capacity	Length	Width	Lift Range			Casters		Guide Tubes	Floor Locks	Shipping Weight
				Low	High	Lift	Swivel	Rigid			
HT-500-FR	500 lb	30"	20"	30"	48"	18"	2	2	2	1	142
HT-2388-05	500 lb	30"	20"	28"	46"	18"	2	2	2	1	173
HT-2368-05	500 lb	30"	20"	26"	44"	18"	2	2	2	1	180
HT-2346-05	500 lb	30"	20"	24"	40"	16"	2	2	2	1	176
HT-2324-05	500 lb	30"	20"	22"	36"	14"	2	2	2	1	170
HT-2302-05	500 lb	30"	20"	20"	32"	12"	2	2	2	1	164
HT-2338-2F	2000 lb	30"	20"	30"	48"	18"	2	2	2	1	215
HT-2388-2F	2000 lb	30"	20"	28"	46"	18"	2	2	2	1	216
HT-2368-2F	2000 lb	30"	20"	26"	44"	18"	2	2	2	1	224
HT-2346-2F	2000 lb	30"	20"	24"	40"	16"	2	2	2	1	220
HT-2324-2F	2000 lb	30"	20"	22"	36"	14"	2	2	2	1	213
HT-2302-2F	2000 lb	30"	20"	20"	32"	12"	2	2	2	1	208
HT-3338-2F	2000 lb	30"	30"	30"	48"	18"	2	2	2	1	276
HT-3388-2F	2000 lb	30"	30"	28"	46"	18"	2	2	2	1	274
HT-3368-2F	2000 lb	30"	30"	26"	44"	18"	2	2	2	1	284
HT-3346-2F	2000 lb	30"	30"	24"	40"	16"	2	2	2	1	280
HT-3324-2F	2000 lb	30"	30"	22"	36"	14"	2	2	2	1	274
HT-3302-2F	2000 lb	30"	30"	20"	32"	12"	2	2	2	1	268
HT-3438-2F	2000 lb	48"	30"	30"	48"	18"	4	0	4	2	460
HT-3488-24	2000 lb	48"	30"	28"	46"	18"	4	0	4	2	472
HT-3468-24	2000 lb	48"	30"	26"	44"	18"	4	0	4	2	482
HT-3446-24	2000 lb	48"	30"	24"	40"	16"	4	0	4	2	478
HT-3424-24	2000 lb	48"	30"	22"	36"	14"	4	0	4	2	472
HT-3402-24	2000 lb	48"	30"	20"	32"	12"	4	0	4	2	466

* Customized sizes and capacities are available to meet customer requirements.