



Engineering & Manufacturing

Half a Century of Precision Lifting

HT and EL Series – Hydraulic Lift Tables (Die Carts)

3000 to 6000 lb capacities

The Medium Duty HT and EL series is an industrial material handling lift table typically used as a die cart. Key features include large size and capacity. A wide range of sizes and options are available to suit the customer's specific material handling requirements.

Their rugged construction consists of a heavy steel frame. The top is guided by exceptionally rigid triple telescoping guide tubes. These tables are designed to last for decades with very little maintenance in the most demanding environments.

These lift tables are engineered with ergonomics and productivity in mind. The high capacity hydraulic system allows the operator to quickly and easily adjust the height of the table with a high level of precision. This allows the operator to have better access to their work piece or to load/unload materials between equipment or storage at different loading levels with less effort.

These tables are equipped with a tow bar to provide mobility when coupled to tow capable equipment such as a forklift. High capacity, large diameter steel (standard) or poly-steel (optional) casters provide low rolling resistance over most surfaces. The position of the table can be anchored through its telescoping floor locks.

Many options are available to improve ergonomics and productivity. Easier on/off load transfer through conveyor or ball transfer roller tops and manual or electric hydraulic push pull mechanisms.

Standard sizes and capacities range from 30" x 30" to 30" x 48" tops and 3000 to 6000 lbs. Custom designs are possible for your specific needs. Lexco Engineering and Manufacturing has over 50 years of experience and knowledge, which translates into a valuable resource in the material handling industry. Tables with overhanging tops, mounting hole patterns, custom dimensions, and much more can be accommodated.

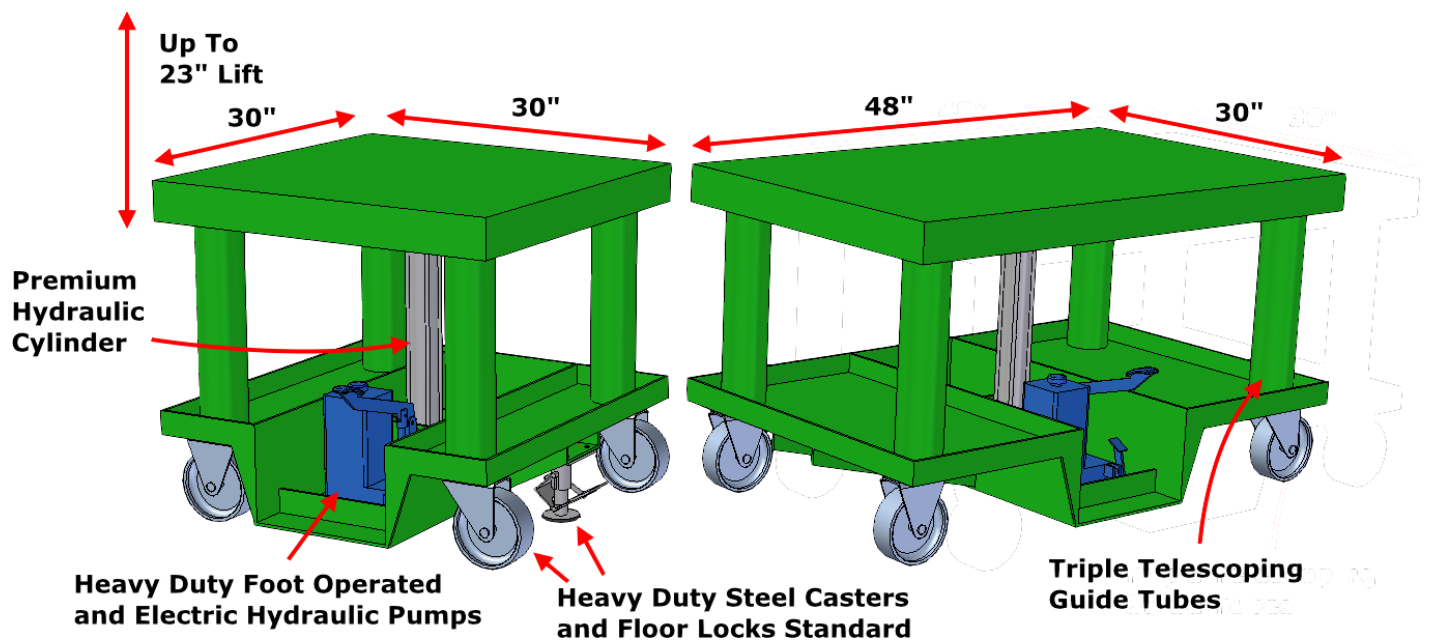

Lexco Engineering & Manufacturing

PO Box 47, Lansdale, PA 19446 | Phone: 215-699-7031 | Fax 215-699-3836 | <http://www.lexcoeng.com>



HT and EL Series – Hydraulic Lift Tables (Die Carts)
3000 to 6000 lb capacities

Model Number Identification*

[Lift Type Code]-[Table Top Dimension Code][Capacity Code]-[Lift Stroke Code]-[Caster Code]-[Power Option]

Example 1

- Requirements
 - Foot operated hydraulic pump
 - Top size: 30" x 30" top
 - Capacity: 3000#
 - Lift range: 28" – 48" (20" stroke)
 - Casters: Steel
- Model Number: HT-3033-20-A

Example 2

- Requirements
 - Electric hydraulic pump (12V DC)
 - Top size: 30" W x 48" L
 - Capacity: 4000#
 - Lift range: 31" - 54" (23" stroke)
 - Casters: Poly-Steel
- Model Number: EL-3044-23-B-DC

Lift Type Codes

HT: Foot operated pump
EL: Electric hydraulic pump

Table Top Dimension Codes

Width x Length
303: 30" x 30"
304: 30" x 48"
XXX: Custom (specify)

Capacity Codes

3: 3000#
4: 4000#
5: 5000#
6: 6000#

Lift Stroke Codes

Stroke (Low – High)
Based on top style A. Other height combinations are available upon request.
16: 16" (24" – 40")
18: 18" (26" – 44")
20: 20" (28" – 48")
22: 22" (30" – 52")
23: 23" (31" – 54")

Fixed heights and custom lift ranges are available.

Caster Codes

A: Steel
B: Poly-Steel
C: Phenolic

Power Option (EL lift type only)

AC: 120/240V AC 1 phase (wired for 110V AC 1 phase)
DC: 12V DC with battery and 120V AC onboard charger

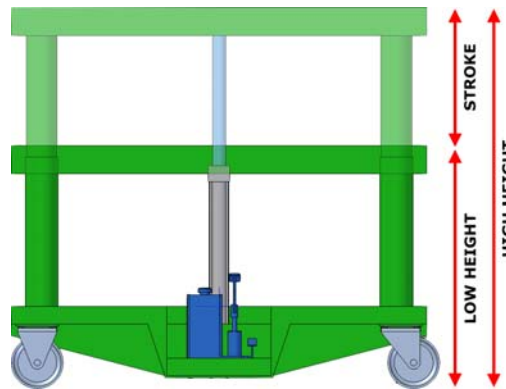

Available Options

Push Pull Mechanisms (powered or manual), Roller Conveyor Top, or Ball Transfer Top for easy die transfer.
Removable Die Pins, Clamps, and Safety Chain Loops to captivate die.
Tow Tongue to attach die cart to drive unit.

* Customized sizes and capacities are available to meet customer requirements.